

BRAZED PLATE HEAT EXCHANGERS



MOUNTING AND OPERATION MANUAL

Contents

Mounting and operation manual of braze plate heat exchangers..... 2

1. General information3
2. Safety instructions3
3. Installing and mounting4
4. Connections5
5. Installation using solder (sweat), welding and threaded connections.6
6. Initial operation7
7. Operation.....7
8. Protection against freezing.....8
9. Fouling, scaling, clogging8
10. Cleaning9
11. Corrosion9
12. The operational conditions and nomenclature of Eko Air BPHE. 11
13. Connection scheme 12
14. The insulation mounting instructions..... 13

DECLARATION OF CONFORMITY 14

MOUNTING AND OPERATION MANUAL OF BRAZED PLATE HEAT EXCHANGERS

CAUTION!

- Please carefully read the entire manual prior to installation and operation. Otherwise, it may cause injury or equipment damage.
- Upon receipt of the BPHE delivery, all claims about external damage or incomplete consignments should be reported in writing to the logistic company.
- BPHE design can bears sharp edges. Always use safety gloves and handle with caution.
- Beware hot surfaces. During the operation process the surfaces of the BPHE might reach high temperatures.
- (Caution! Hot surfaces) ->



1. General information

The Company Eko Air Ltd. designs and manufactures brazed plate heat exchangers (further – BPHE or heat exchanger), capable to withstand loads, created by temperature and pressure fluctuations.

The Eko Air BPHEs are available in a wide spectrum of sizes, can be used for different working environments and pressures. The typical examples of working environments are synthetic and mineral oils, water (excluding sea water), solutions of ethylene- and propyleneglycol, refrigerating mediums (excluding natural mediums – ammonia and carbon dioxide, as well as usage in the transcritical cycle).

The designations of the present manual correspond to the whole nomenclature of the Eko Air heat exchangers. It is necessary additionally to take in account the specifications of the order of every single heat exchanger.

The mounting and operation of brazed plate heat exchangers should be performed by expressly educated specialists, taking in account all state and international norms and regulations on the matters of safety and accident protection.

Eko Air manufactures different types of plates that allow using the BPHE for different purposes. The choice of the heat exchanger and the type of plates is determined by the temperature schedule and allowable pressure drop.

The Manufacturers information about the type of BPHE, model, date of manufacture, serial number, manufacturer and technical parameters are specified on the label on BPHE.

The Eko Air heat exchangers are defined as equipment working under pressure in accordance with the Directive 97/23/EC of the European Parliament and of the Council.

2. Safety instructions

 The heat exchangers are allowed to undergo works and repairs only in case the unit is not under pressure and the temperature of its surface is below 40°C!

Using the heat exchanger by high temperature provide it with necessary heat insulation. Be cautious close to the heat exchanger to avoid scorches!

 In case the heat exchanger is operated in I category environments or with dangerous liquids and gasses, comply with the obligatory terms of safety!

 Do not drop the brazed plate heat exchanger from heights! During the mounting process protect the heat exchanger from shocks!

Before installing the heat exchanger make sure the unit was not harmed during the transportation and storage.

3. Installing and mounting



BPHE mounting position must ensure sufficient space around the unit to be able to carry out maintenance works and service. Installation position must allow the possibility of venting and drainage.

Upon mounting the BPHE in the installation, the most suitable orientation is vertical (up-right). All other positions may cause loss in heat transfer efficiency or mechanical problems.

! For two-phase operation, BPHE must always be installed in a vertical position (evaporator, condenser).

! Never install a BPHE with the connectors facing down. Use mounting brackets for BPHE fixation or support them on their basis. It is not recommended to support the heat exchangers just on the piping (e.g. on connectors or close pipework).

Installing a heat exchanger, the maximum forces and torques must not be exceeded.

| The diameter of connection | Displacement Fs (kN) | Tension Ft (kN) | Bending moment Mb (Nm) | Torque Mt (Nm) |
|----------------------------|----------------------|-----------------|------------------------|----------------|
| 1/2" (DN15) | 3.5 | 2.5 | 20 | 35 |
| 3/4" (DN20) | 12 | 2.5 | 20 | 115 |
| G 1" (DN25) | 11.2 | 4 | 45 | 155 |
| 1 1/4" (DN32) | 14.5 | 6.5 | 87.5 | 265 |
| 1 1/2" (DN40) | 16.5 | 9.5 | 155 | 350 |
| 2" (DN50) | 21.5 | 13.5 | 255 | 600 |
| 2 1/2" (DN65) | 44.5 | 18 | 390 | 1000 |

During the mounting of the heat exchanger maximal loads on the fastening bolts must not be exceeded.

| Weld stud | Area of tension mm ² | Extension strength Ft (N) | Torque Mt (Nm) |
|-----------|---------------------------------|---------------------------|----------------|
| M8x20 | 36.6 | 1060 | 16 |
| M10x25 | 58 | 2250 | 32 |
| M12x25 | 84.3 | 3270 | 56 |

4. Connections

In most standard applications for BPHE, the highest thermal efficiency can be achieved through counter-current flow where the two fluids flow in opposite directions through the BPHE.

Entrance of the primary BPHE channel is marked with a dot.

The circuit with the higher temperature and pressure should be connected to the primary channel of the BPHE in case of the standard performance. The illustration provides the example of connection of a one-way standard BPHE “water-water”. It is necessary to connect the heat exchanger in counter-current flow to reach the maximal efficient operation of the BPHE: the hot water supply from the heating system to the connector 1.1 (Q1), exit – 1.2 (Q4); the entrance of cold water to the connector 2.2 (Q3), exit – 2.1 (Q2). It can be explained with the fact that the secondary circuit of the BPHE has one more channel than the primary circuit. In this case, the hotter heat carrier is placed between two cold channels. This layout allows reducing the amount of heat losses.

The operation of the BPHE during the change of phase of the substance. Using the BPHE in refrigeration units requires the channels of the cooling agent to be between the channels of the water circuit. It is required to make the processes of condensation / evaporation more effective and complete. In case the cooling agent circuit is mounted incorrectly the temperature of evaporation becomes reduced, the possibility of unequal distribution of the cooling agent in the BPHE appears, which can also lead to reduction of efficiency, the risk of freezing of the heat exchanger appears, which as the final result might lead to the damage of the BPHE.

Using the BPHE as a condenser, the gaseous cooling agent entrance is connected with the upper connection of the primary circuit 1.1 (Q1), the exit of the liquid cooling agent – 1.2 (Q4). The water / ethylene glycol circuit should be connected as a counter-current flow, the entrance – to the bottom connector of the secondary circuit 2.2 (Q3) and exit – to the upper connector of the secondary circuit – 2.1 (Q2).

Using the BPHE as an evaporator, the entrance of the liquid cooling agent should be connected to the bottom connector of the primary circuit 1.2 (Q4), the exit of the gaseous cooling agent – to the upper connector of the primary circuit 1.1 (Q1).

The water / ethylene glycol circuit should be connected as a counter-current flow, the entrance – to the upper connector of the secondary circuit 2.1 (Q2) and exit – to the bottom connector of the secondary circuit – 2.2 (Q3). The regulating expansion valve should be mounted as close as possible to the entrance of the liquid cooling agent.

In case of use of heat exchangers for non-standard or special schemes contact the manufacturer or the representative of the company for further information.

The illustration provides the numeration of the connectors (the letters are used in accordance with symbols used by the heat exchanger calculation software).

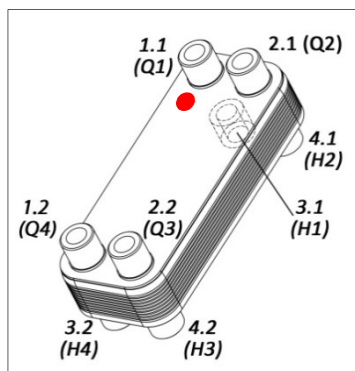

! **Attention:** Make sure that the BPHE is not exposed to severe vibration or pulsation. To avoid that, vibration absorbers (e.g. mufflers) must be installed in pipework system, or between the BPHE and other equipment must be vibration-absorbing material. The BPHE lifetime will be significantly reduced, if there is insufficient system and flow control. The following are some of the factors that have adverse effect on the life of the product.

The following impact should be avoided:

- Excessive control valves;
- Excessive pressure variations in the different channels of the system;
- Poor quality control valves;
- Improper controller settings.

! **Attention:** Before connecting BPHE to new or renovated pipework systems, you have to ensure that pipework is free from garbage and/or coarse particles which could clog the BPHE fluid channels. To increase the safety of operation of the BPHE the installation of filters on the entrance of the mediums is recommended, to prevent the getting into the channels of small particles.

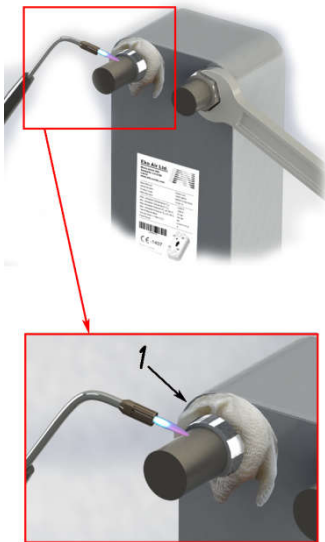

5. Installation using solder (sweat), welding and threaded connections.

Soldered (sweat) connections

Clean and degrease the solder surfaces (both – on the copper pipes and on the BPHE connectors).

Polish the surface to remove oxides. Solder the surfaces. To prevent oxidation during soldering process, fill the inside of the BPHE with nitrogen. Point the flame towards the connectors. Do not point the soldering equipment's flame against the BPHE, do not exceed soldering process temperature higher than 650°C (1200°F). Soldering material: with silver content not less than 45%. Use a wet cloth (1) to prevent overheating of the BPHE. Make sure the BPHE and tubes stay static during soldering process.

Warning: excessive heat can lead to copper melting while damaging the BPHE.

Welded connections

Use TIG (GTAW) welding.

Use a wet cloth (1) to prevent overheating of the BPHE.

To prevent oxidation during soldering process, fill the inside of the BPHE with nitrogen.

Threaded connections

Mount the BPHE first; add the pipes using threaded connectors.

The supply pipes of the BPHE should be fixed to avoid stress or tension of the thread connections.

In case the buyer orders a junction or flange connection separately from the BPHE, the Eko Air Ltd. does not feel responsible for bad quality braze/sweat of given connectors or possible accidents.

6. Initial operation

Before putting the BPHE into operation, it has to be checked whether the specified maximum operating parameters provided by the manufacturers label are not going to be exceeded.

Check any fluid connections for potential leaks.

The pumps that supply the BPHE have to be equipped with shut-off valves. Pumps capable of generating a higher working pressure than the BPHE is designed for must be fitted with safety valves. The system has to be air-free to avoid interference with BPHEs function. To avoid pressure surges, pumps have to be turned on while the valves are closed.

It is necessary to check whether the pulsations and impulses are not transmitted to the BPHE. The correctness of the mounting of the pipelines has to be checked to avoid unnecessary loads on the connectors.

To avoid hydrodynamic shocks and the traces of air in the system, the cut-off and air escape valves have to be opened during launch. The valves on the supply and return lines must be opened slowly as much as possible.

The air left in the system and BPHE reduces the operation efficiency, as well as increases the risk for corrosion.

7. Operation

! The exceeding of maximally permissible temperatures and pressures, provided on the label of the BPHE, is not allowed during operation.

! The operation of the BPHE under strong drops of temperature and jumps of pressure might lead to the damaging of the BPHE and is not tolerated. In case strong drops of temperature, jumps of pressure and the hydraulic shock have occurred, it is necessary to stop the operation of the BPHE, inspect visually the unit and in case of necessity perform the hydraulic pressure test.

During operation avoid temperature drops bigger than 100°C between the primary and the secondary channels.

! It is prohibited to use aggressive mediums that can lead to corrosion of the materials of the BPHE.

If the BPHE is installed between the control valve and the differential pressure regulator it must be verified, if there is not generated negative pressure while closing both flow/pressure adjusting devices that can cause blockages in the system.

Regularly check the efficiency of the control device functionality and control the obtained values. It would allow determining on time the interference in the operation of the BPHE (the changes of the hydraulic parameters of the system, the necessity to perform washing-out).

Make sure to avoid any working conditions during operation which may exceed the systems design limiting parameters and operation instructions.

Before switching off of the BPHE make sure that all the pumps are switched off. To stop the operation of the BPHE slowly close the supply valves (first should be terminated the side with the highest pressure). After long downtime of the object it is required to fully drain and clean the BPHE. It is made due to the danger of freezing, as well as in the BPHE are used dangerous and hazardous liquids, because the not completing of the actions might lead to biological pollution.

While terminating the operation of the BPHE, it is required to stop the primary channel first and only afterwards - the second. Restarting the operation, the secondary circuit is launched first and only afterwards - the second, to reduce the possibility of heat exchanger overheating.

Operating the BPHE by temperatures below 0°C (32°F) or above +40°C (104°F), is required to use corresponding insulation.

In case of non-standard use not described in the manual, contact the manufacturer or the representatives of the company for further information.

8. Protection against freezing

Freezing can lead to a severe damage of the BPHE due to formation of ice. If operating conditions approach the freezing point, antifreeze agents, such as solutions of glycol, must be applied.

The freezing might lead to damage of the BPHE.

Using the BPHE in refrigeration units as an evaporator, thoroughly check the parameters of the BPHE with corresponding calculations. Use only corresponding regulation devices. Avoid using of a vacuum pipe.

Use corresponding insulation for the BPHE.

9. Fouling, scaling, clogging

The reason of clogging of the BPHE and the emerging of scale can be reasoned with several factors, for example, the velocity of flow, temperature, the quality of water.

To prevent the emerging and precipitation of small particles in the BPHE (> 1mm) install a corresponding filters on the inputs to the heat exchanger (100 µm). On the contrary, the clogging of the plate channels becomes possible, which can also lead to the reduction of efficiency, the increase of pressure losses or the freezing of the heat exchanger operated as an evaporator.

The precipitation of small particles can be avoided by providing high turbulence of the flow.

Factors, contributing to the emerging of scale and other deposits in hot water supply systems:

- The quality of water (see table 11.1)
- The velocity of heated water. Excessive heating contributes to the emerging of calcium deposits.
- The overly small flow of warm water in particular systems reduces the turbulence of the flow. It is a common reason for the reduction of the self-cleaning effect. In this case the exuding calcium is precipitating on the plates. It is very topical for hot water supply systems.
- In regions, where the content of calcium in water is high and an excessive risk of emerging of the deposits of small particles is topical, it is recommended to desalt and to mitigate the water.
- The high temperature of plates in hot water supply systems increases the possibility of emerging of scale and the risk of the deposit of small particles. The temperature of the walls of the BPHE should not exceed 60°C (140°F).

10. Cleaning

The cleaning of the BPHE should be regularly performed to avoid the emerging of any deposits in the channels of the heat exchanger. The cleaning must be performed in counter-current flow regimen, using special cleaning agents and weak acids. It is necessary to check the chemicals and cleaning agents for the reactions with copper and stainless steel. After the cleaning the BPHE has to be rinsed with clean water.

It is necessary to obtain full information on the substances from the manufacturers of the cleaning agents, to verify whether the substances are capable to have an impact on the materials of the BPHE. The cleaning has to be performed under the instructions of the safety and accident prevention, and corresponding to the recommendations of the manufacturers of the cleaning agent.

The noncompliance to these conditions might lead to the damage of the BPHE.

11. Corrosion

! The brazed plate heat exchanger consists from brazed corrugated plates made from stainless steel and copper braise. It is important to avoid factors, contributing to corrosion of steel and copper, as well as contributing to the washing out of copper during the exploitation. The noncompliance to these conditions might lead to the damage of the BPHE.

The basic properties of water, causing the corrosion of metals: electroconductivity, the pH level, the hardness of water, the alkalinity, the concentration of chloride-, sulfate-ions and unbound oxygen, the content of sulfuric acid salts. The high content of chlorides and sulfates increases significantly the probability of corrosion.

The oxidizing substances (for example, chlorine) strengthen the polarization and contribute to the anodic dissolution.

! To avoid electrochemical corrosion:

1. Heat exchanger must be grounded. The electric potential between heat exchanger and the ground must be equal to 0. Ground impedance must be $R < 4 \Omega$.
2. The emerging of the galvanic effect, which occurs due to use of different metals, cannot be tolerated. The arrangements for the separation of galvanic pairs have to be envisaged, for example, using bronze or stainless steel adapters and connectors.
3. Comply with the recommendations of the manufacturer on the allowed concentrations of impurities in the water (see table 11.1).

The recommended values of properties and impurities of water for BPHE:

Table 11.1

| <i>Parameter</i> | <i>Concentration [mg/l]</i> | <i>Parameter</i> | <i>Concentration [mg/l]</i> |
|--|--|---|-----------------------------|
| Electroconductivity | 10-500 $\mu\text{S cm}^{-1}$ | Aluminum (Al) | > 0.2 mg/l |
| pH | 7.5 – 9.0 | Iron (Fe) | < 0.2 mg/l |
| Hardness | 1.2 | Manganese (Mn) | < 0.1 mg/l |
| (HCO_3^-) | 70 – 300 | Ammonia (NH_3) | < 2 mg/l |
| Sulfates (SO_4^{2-}) | < 70* < 250** | Nitrates (NO_3) | < 100 mg/l |
| (HCO_3^-)/(SO_4^{2-}) | > 1.0 | Unbound carbon dioxide (CO_2) | < 5.0 |
| Sulfites (SO_3), unbound chlorine (Cl_2) | < 1.0 | Nitrogen sulfide (H_2S) | < 0.05 |
| Chlorides (Cl), in dependence of temperature | < 25 ppm (130°C) < 150 ppm (80°C) < 300 ppm (60°C) | Copper | 2.0 mg/l |

* - recommended value

** - maximal tolerated value

12. The operational conditions and nomenclature of Eko Air BPHE.

The internal volume of the BPHE can be determined after the formula:

$$V_{\max} = V_{\text{ch}} \times N,$$

where V_{\max} - internal volume of the heat exchanger
 V_{ch} - volume of the channel
 N - amount of channels

Table 12.1

| Model | Maximal operation pressure (PS), bar | Maximal operation temperature, °C | Test pressure (PT), bar | Volume of a single channel | Maximal amount of channels, pcs. | Maximal flow rate, m ³ /h |
|-----------------|--------------------------------------|-----------------------------------|-------------------------|----------------------------|----------------------------------|--------------------------------------|
| | LB/NB | | LB/NB | (V) | | |
| 238 | 16/31 | +200 | 28.4/55 | 0,039 | 50 | 5,3 |
| 328 | 16/31 | +200 | 28.4/55 | 0,055 | 50 | 5,3 |
| 464/466/ 468 | 16/31 | +200 | 28.4/55 | 0,078 | 60 | 6,9 |
| 138/136/ 134 | 16/31 | +200 | 28.4/55 | 0,082 | 140 | 13 |
| 538/536/ 534 | 16/31 | +200 | 28.4/55 | 0,116 | 140 | 13 |
| 758/756/ 754 | 16/25 | +135 | 28.4/40 | 0,279 | 200 | 39 |

Table 12.2

| Model | A | B | C | D | E | L | Weight (empty) |
|------------------|-----|-----|-----|-----|------|--------------|----------------|
| | mm | | | | | NB, mm | LB (NB), kg |
| 238 | 90 | 226 | 43 | 182 | 22,1 | 11.1+2,35*N | 0,965+0,062*N |
| 328 | 90 | 323 | 43 | 279 | 22,1 | 11.1+2,35*N | 1.293+0,089*N |
| 464/468 | 94 | 463 | 43 | 415 | 22,1 | 14.95+2,35*N | 1,811+0,128*N |
| 138/136/ 134 | 123 | 380 | 64 | 320 | 27,1 | 14.83+2,25*N | 2,338+0,13*N |
| 538 /536 /534 | 123 | 531 | 64 | 471 | 27,1 | 14.83+2,25*N | 3.024+0,186*N |
| 758/756/ 754 | 264 | 547 | 174 | 456 | 27,1 | 13.55+2,35*N | 6.983+0,389*N |

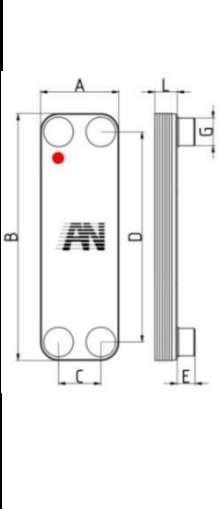

13. Connection scheme

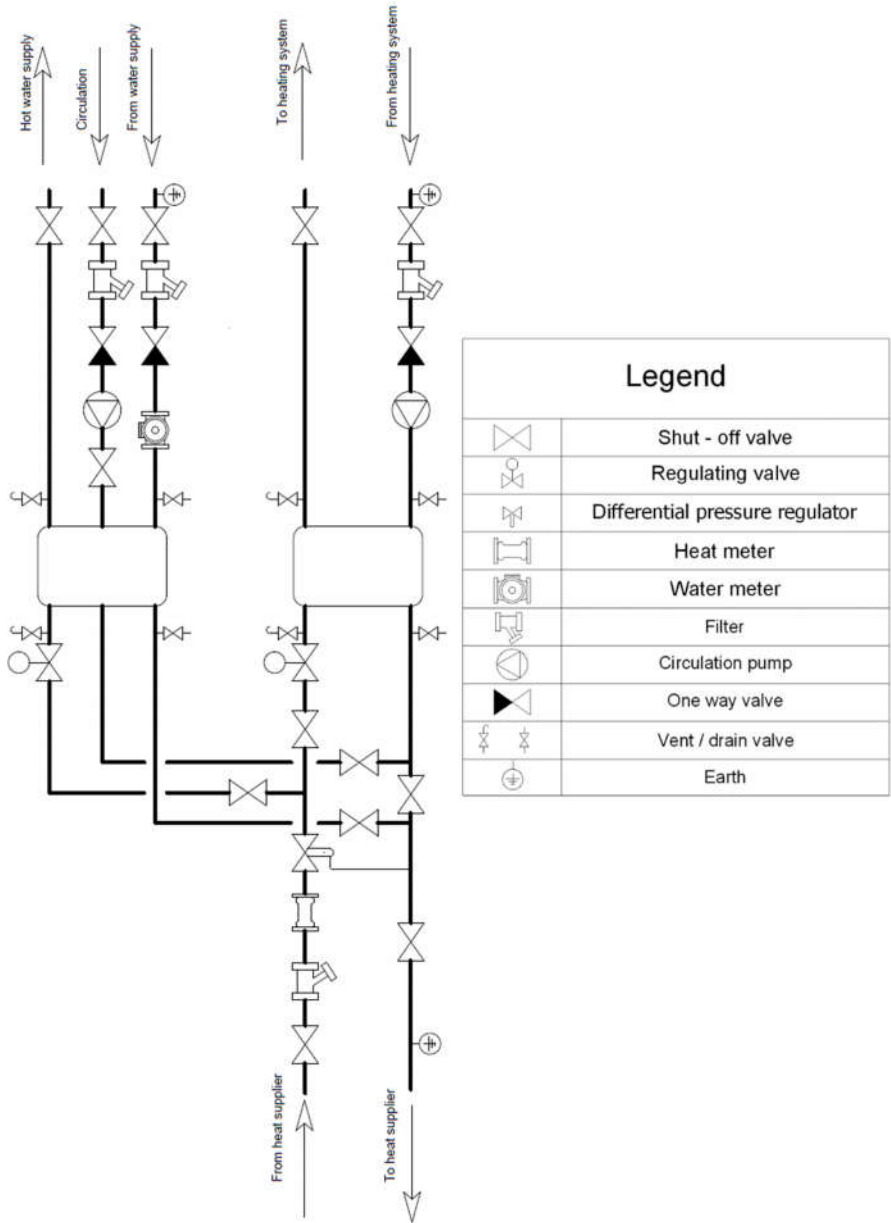

14. The insulation mounting instructions

The mounting of heat insulation has to be performed after completing of the soldering and welding works and when the equipment has cooled.

Before installation of the insulation package, make sure that the appropriate size is chosen and it complies with the surface of the BPHE.

As the insulation used is sectional, its mounting can be performed on already installed and functioning heat exchangers.

Warranty

Eko Air provides warranty terms to its products equal to 12 months from the date of selling / purchasing, if it is not otherwise determined. The warranty considers defects of material and the product, which occurred during the manufacturing process. The warranty is not covering defects and damage that were created during the mounting and operation (including corrosion and freezing of the heat exchanger).

The basics of operational properties of the Eko Air BPHE are the correct mounting, service and operation conditions, which are described in the provided manual. Eko Air does not bear responsibility for losses, occurred due to noncompliance to these conditions.



Attention:

The mounting and servicing of the BPHE has to be provided in compliance with the present manual. In case this condition is not fulfilled Eko Air does not bear responsibility for the operation of the BPHE.

For additional information contact the manufacturer or his representatives.

DECLARATION OF CONFORMITY

(in accordance with ISO/IEC 17050-1)

Nr.001-2016

| Declaration of conformity of a pressure vessel | |
|---|---|
| Operative Conformity Assessment according to Pressure Equipment Directive 97/23/EC of the European Parliament and the Council of 29 May 1997. | |
| SIA EKO AIR - Brazed Plate Heat Exchanger | |
| Type: | Type approval certificate N ^o and date of issue: |
| NB238, NB328, NB464, NB466, NB468, NB134, NB136, NB138, NB534, NB535, NB536, NB537, NB538 | 2.3.12/A1/016 (17.12.2012) |
| LB238, LB328, LB464, LB466, LB468, LB134, LB136, LB138 | 2.3.13/A1/007 (28.03.2013) |
| LB534, LB535, LB536, LB537, LB538, LB754, LB755, LB756, LB757, LB758 | 2.3.13/B/010 (04.06.2013) 2.3.13/C1/011 (04.06.2013) |
| NB754, NB755, NB756, NB757, NB758 | 2.3.13/B/012 Rev.1 (20.02.2014) 2.3.13/C1/013 Rev.1 (20.02.2014) |
| SL238, SL328, SL464, SL466, SL468, SL134, SL136, SL138, SL534, SL536, SL538 | 2.3.16/B/005 (11.04.2016) 2.3.16/C1/006 (11.04.2016) |

| | |
|--|--|
| Standards: | Pressure Equipment Directive 97/23/EC EN13445-3 EN13445-5 EN10028-7 |
| Conformity assessment procedure: | Module A1 Module B Module C1 |
| Name and address of the notified body: | LRTDEA TÜV Rheinland Group, Ltd 3/C2 Ieriķu Street, Riga, Latvia |
| Notification number of Notified Body: | 1407 |
| CE sign on pressure equipment: | CE 1407 |
| Manufacturer: SIA EKO AIR Legal address: Brivibas street 47-8, Riga, LV-1010, Latvia Factory address: Miera street 30D, Salaspils, LV-2169, Latvia Tel +371 66066639 E-mail: ekoair@icloud.com www.ekoair.lv | The manufacturer herewith certifies that construction, production and examination of pressure vessels are in conformity with European Pressure Equipment Directive 97/23/EC. Rostislavs Li / Managing Director Date of issue: 12.04.16 Place of issue: Salaspils, Latvia |

THE PRODUCTS AND MANUFACTURING PROCESSES CORRESPOND TO THE REQUIREMENTS OF THE FOLLOWING STANDARDS:

LVS EN ISO 9001:2009 (ISO 9001:2008)

PED – 97/23/EC - TÜV Rheinland Group



Production site

SIA Eko Air
Miera iela 30D, Salaspils,
Latvija LV-2169

☎: +371 66066639
✉: ekoair@icloud.com

www.ekoair.lv